



Main Features	
Application	<p>Solar Pump Station involves all necessary components for everyday efficient operation, incl. complete electrical wiring. Only the collector temperature sensor needs to be connected.</p> <p>The pump station permits connecting an auxiliary el. heating element of 2-3 kW output. For this purpose, the pump station is equipped with a special socket.</p> <p>The heating element is power supplied through a separate cable that is included in the pump station. This cable shall be connected to the power input switched by Ripple control. The Ripple control contactor that blocks this input during high-tariff shall be sufficiently sized to exceed safely the output of the heating element installed.</p> <p>Neither a heating element not a contactor are included in supply.</p>
Description	<p>The pump station consist of Para ST 25 / 7-50 / iPWM2 pump, SRS1 T controller, non-return and safety valves, 2 ball valves, pressure gauge, thermometer, el. wiring, insulation and installation kit. After the control element with end stops is removed and the gland nut released, the ball valves enable easy replacement of O-rings.</p> <p>The pump station further involves:</p> <ul style="list-style-type: none"> <li>• outlet for expansion vessel connection</li> <li>• outlet from safety valve, incl. extension piping led below the pump station for an easy connection</li> <li>• solar system filling, draining and topping-up valves</li> <li>• special socket to connect a heating element of max. 3 kW / 230 V output</li> <li>• 2 temperature sensors connected to a consumer (4 m cable)</li> <li>• solar temperature sensor (2 m cable)</li> <li>• input power cable switched by Ripple control (3 m long, 3 x 1,5 mm<sup>2</sup> cross section, black)</li> <li>• 230 V power supply cable w. el. plug (3 m long, 3 x 1,5 mm<sup>2</sup> cross section, black)</li> </ul>
Flow rate measurement	The pump sends the momentary flow rate value as data to controller where it is displayed.
Installation	on a tank or wall using the installation kit
Working fluid	water-glycol mixture (max. 1:1)

Code corresponding to connection size				
Connection	G 3/4" M	G 1" M	Cu 22 mm	Cu 28 mm
Code	17350	17349	17351	17352

## CSE SOL W SRS1 T-E HDO Solar Pump Station

v1.2\_10/2019

### Data for CSE SOL W SRS1 T-E HDO Pump Station

Max. fluid working temperature	110 °C
Max. working pressure	6 bar
Min. system pressure	1.3 bar with the pump stopped
Flow rate measurement range	2-20 l/min
Heat source switching	potential-free contact
Max. switched current	13 A / 230 V
Power supply	230 V, 50 Hz
Ambient temperature	0 to 40 °C
Max. relative humidity	85% at 25 °C
Insulation material	EPP RG 60 g/l
IP rating	IP20
Overall dimensions	470 x 265 x 120 mm
Total weight	7.1 kg

### Accessories

Code 16942	ETT-N heating element, 2 kW
Code 16943	ETT-N heating element, 3 kW
Code 16940	connector for CSE SOL W SRS1 T-E
Code 7629	Cu 22 x Cu 22 fittings, straight, to connect safety valve to waste pipe
Code 13695	Cu 22 x G 3/4" M fittings, straight, to connect safety valve to waste pipe

### Pump Station Internal Wiring

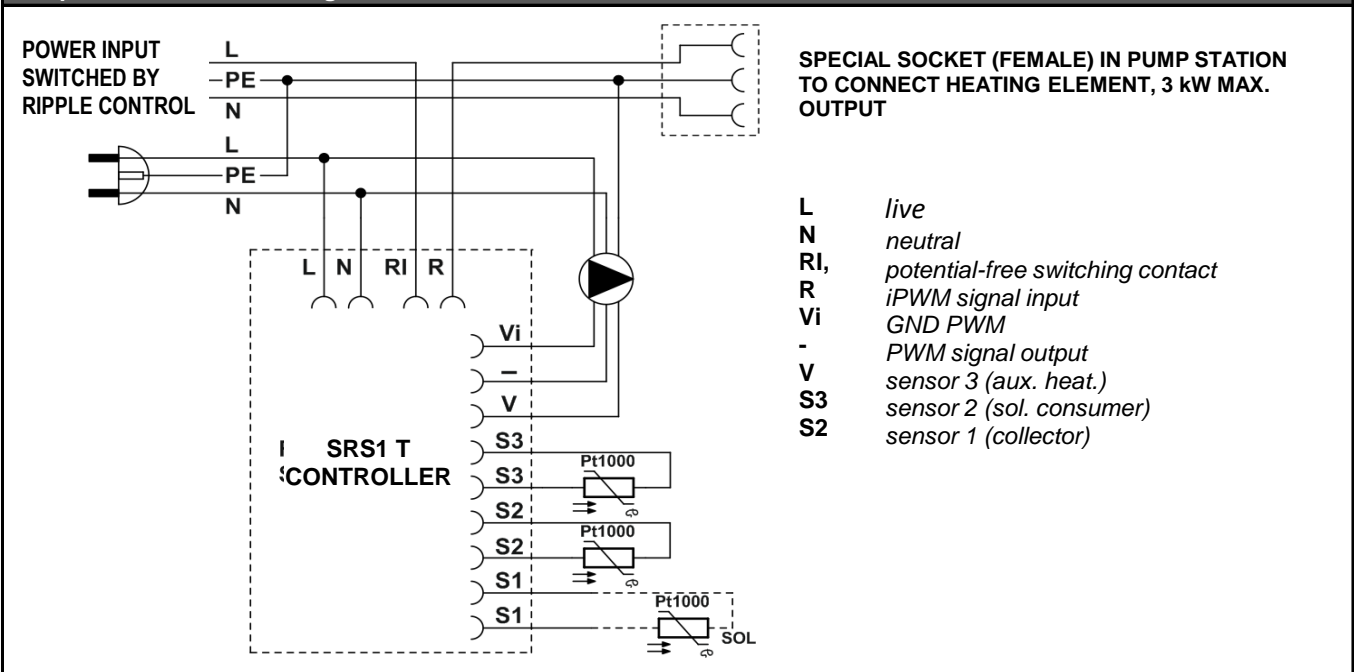

### Pump Station Pressure Drop

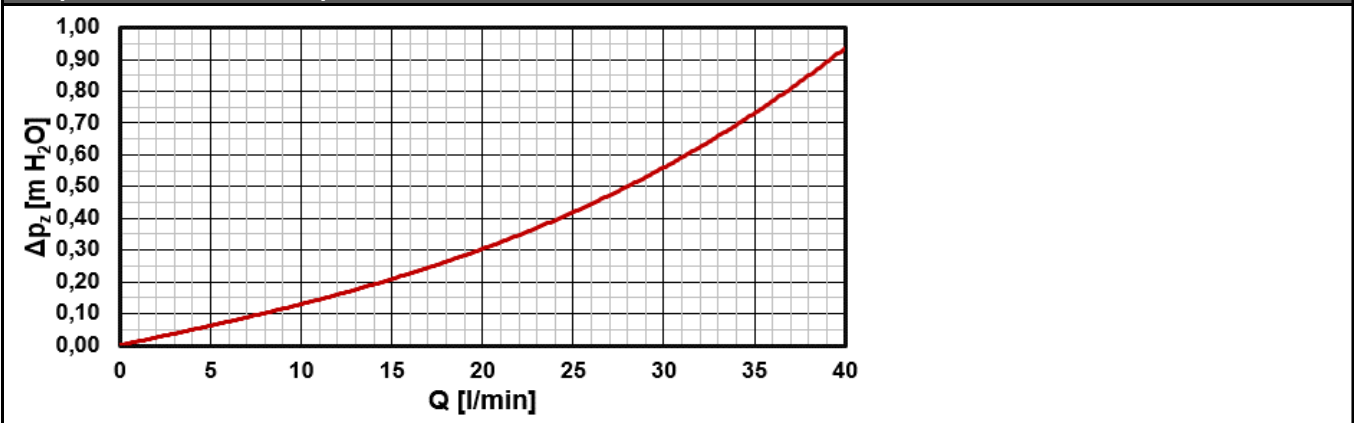

Performance curves for Para ST 25-130 / 7-50 / iPWM2 Pump

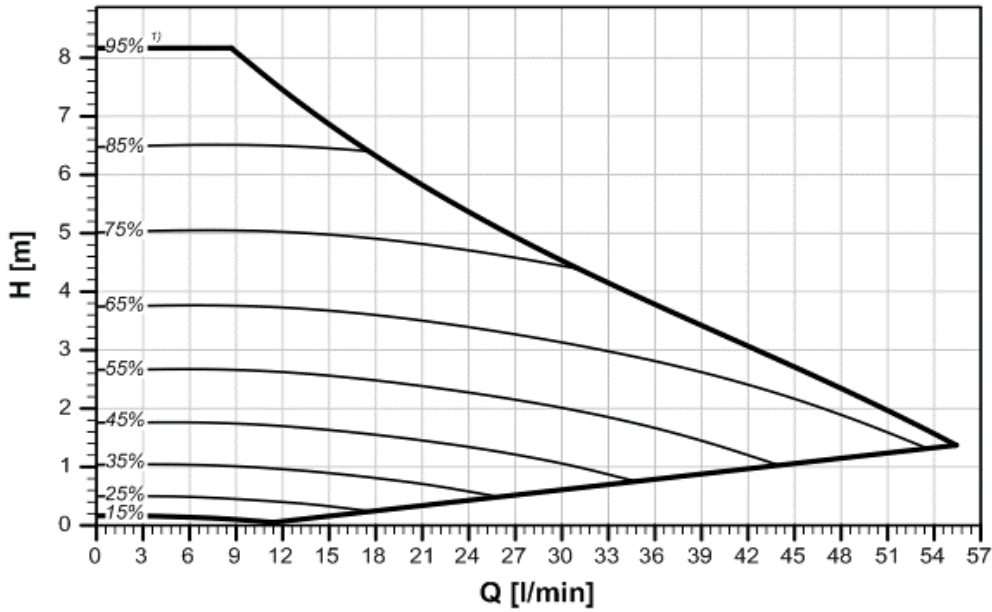

NOTE:  
 1) PWM signal value in %,  
 2) speed in rpm

